

Angle Point End Mill

Date: _____	PO #: _____
Distributor: _____	Location: _____
Contact: _____	Phone: _____
Email: _____	Fax: _____
# of Pieces: _____	Hardness: _____
Material : _____	

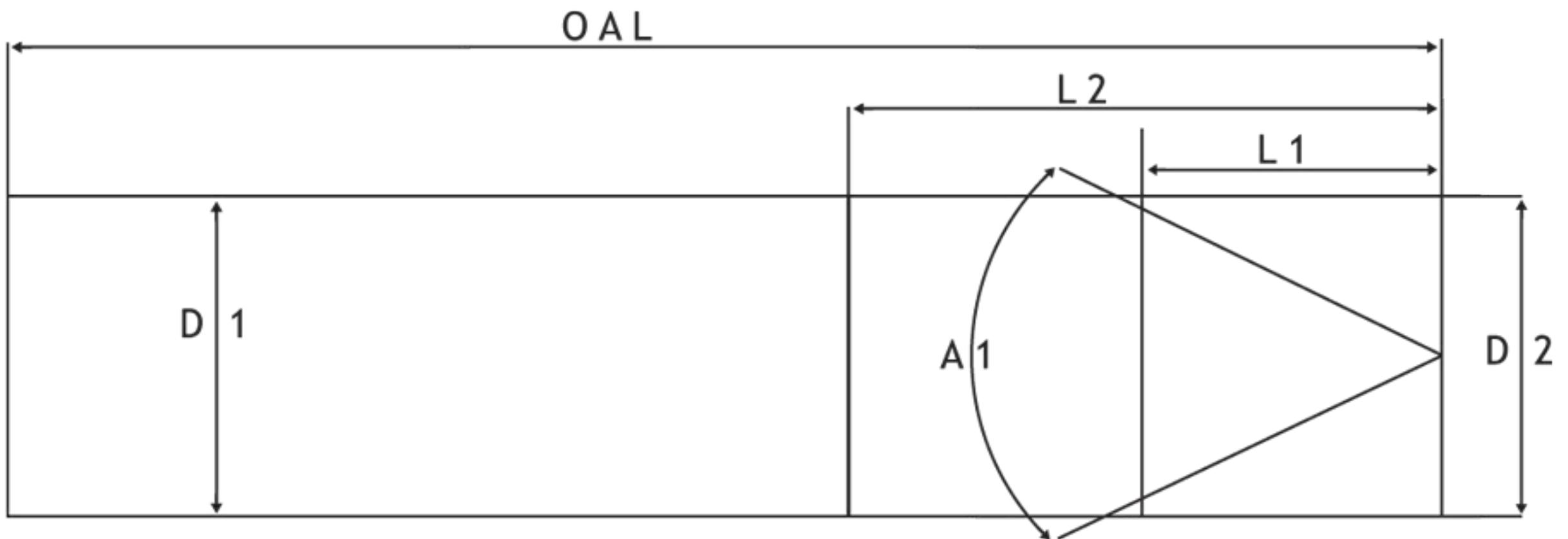

Tool Specifications:

Modify Standard Tool Yes No EDP# _____

Center Cutting: Yes No OAL: _____ A1: _____

Shank Design: _____ # of Flutes: _____

Helix Angle: _____ Coating: _____

D1: _____ D2: _____ L1: _____ L2: _____

Special Instructions: _____

Standard tolerances used unless otherwise specified
.x = ± .1
.xx = ± .01
.xxx = ± .005
.xxxx = ± .0005
Fractions = ± 1/64"
Angular = ± 3°